

## POWER ELECTRONIC CONVERTER HARMONICS

This book, first published in 1995 by the IEEE Press, is now published in paperback form by John Wiley & Sons, Inc. It can be purchased from the Internet at [www.Wiley.com](http://www.Wiley.com)

Here is what reviewers had to say about the book:

**“An excellent treatment of the subject.”**

— Allan Ludbrook, *Ludbrook & Associates*

**“Pulls all the material together and presents it from the viewpoint of a long-time practitioner in the field . . . will be much appreciated by designers, the utilities, and users.”**

— Thomas Barton, *University of Calgary*

Sample schematic from the book.

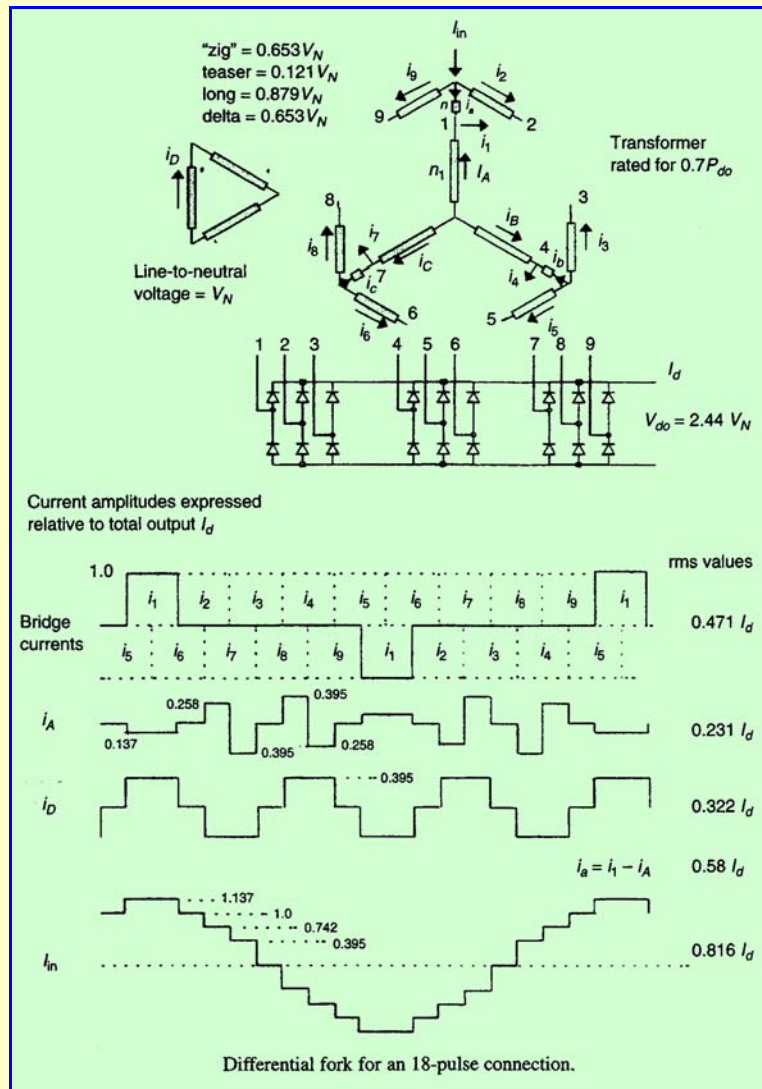

This picture from the book shows a 500 HP, variable speed drive unit powered by an 18-pulse clean power converter. The patented three-phase to nine-phase transformer is in the right side cabinet. This clean power converter was in production in August 1990. It was the forerunner of the many clean power converters in use today. The transformer coil configuration is identical to the one shown in the schematic above.



A recent patent relating to a different construction Clean Power Transformer is shown below.



US006525951B1

(12) **United States Patent**  
Paice

(10) **Patent No.:** US 6,525,951 B1  
(45) **Date of Patent:** Feb. 25, 2003

- (54) **SIMPLIFIED WYE CONNECTED 3-PHASE TO 9-PHASE AUTO-TRANSFORMER**
- (76) Inventor: **Derek Albert Paice**, 114 Rosewood Ct., Palm Harbor, FL (US) 34685
- (\*) Notice: Subject to any disclaimer, the term of this patent is extended or adjusted under 35 U.S.C. 154(b) by 0 days.
- (21) Appl. No.: 10/054,785
- (22) Filed: Jan. 25, 2002
- (51) Int. Cl.<sup>7</sup> ..... H02M 5/00
- (52) U.S. Cl. .... 363/154; 363/153
- (58) Field of Search ..... 363/5, 148, 149, 363/152, 153, 154
- (56) **References Cited**

U.S. PATENT DOCUMENTS

- 5,455,759 A \* 10/1995 Paice ..... 363/126  
5,619,407 A \* 4/1997 Hammon ..... 363/155  
6,191,968 B1 \* 2/2001 Paice ..... 363/148  
6,249,443 B1 \* 6/2001 Zhou et al. .... 363/5

OTHER PUBLICATIONS

"Power Electronic Converter Harmonics" by Derek A. Paice, IEEE Press, ISBN 0-7803-1137-X, 1995.\*

\* cited by examiner

Primary Examiner—Matthew Nguyen

(57) **ABSTRACT**

In an 18-pulse converter system a three-phase to nine-phase auto-transformer with multiple windings per phase is used to power a nine-phase AC to DC converter. The transformer kVA rating is about 55% of the DC load kW. The basic topology is that of a wye connection, but an active delta path is added to allow circulation of the third harmonics necessary for proper operation. The design requires substantially fewer coils than other three-phase to nine-phase auto-transformers. The voltage ratio can be selected so as to give an average DC output from an 18-pulse converter which is generally the same as that of a conventional three-phase bridge rectifier without a transformer. However, the topology described is also suitable for step up or step down of voltage as required. Where necessary to further reduce high frequency harmonic currents, a three-phase ac line reactor may be connected in series with the source of ac power.

7 Claims, 8 Drawing Sheets

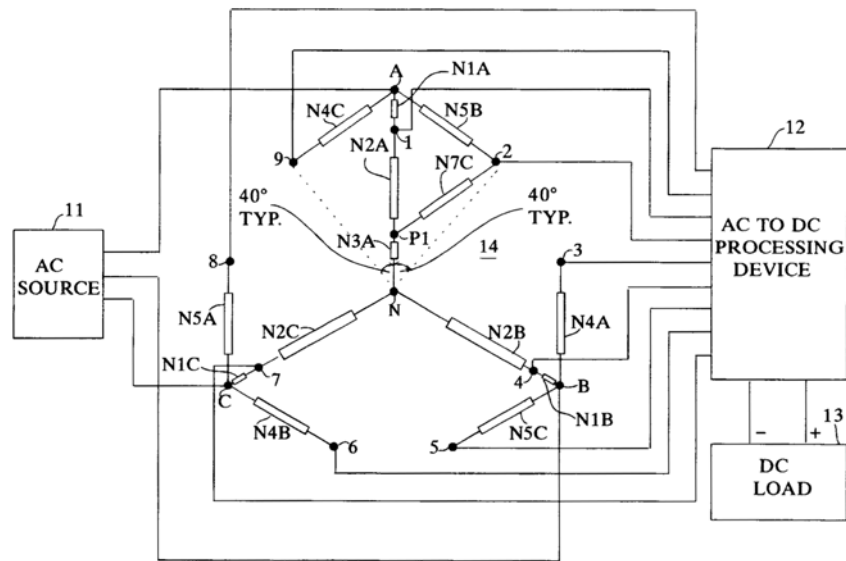

Derek Paice  
May 2005